

Technical characteristics

- Flow rates: from 0,596 to 61,4 lph @ 50Hz
- Max Pressure: 4 MPa (40 bar)
- Ambient temperature: -10 °C + 40 °C
- Max altitude: 1000 m (A.S.L.)
- Fluid operating temperature: -10 °C + 70 °C
- Viscosity up to 1000 mPa•s (1000 cP) (Higher on request)
- Stroke adjustment during operation from 0 to 100%
- Accuracy $\pm 1\%$ on the turndown ratio 10:1
- Multiheads (up to six) solutions
- API 675 compliance
- CE marking
- ATEX Ex II 2 G c IIB T4 compliance
- Protection: IP 55
- Epoxy painting at 125 micron

nEXa series includes plunger and hydraulic diaphragm dosing pumps designed in compliance with **API 675 Standards**; the conformity to the API Standards implies a “heavy duty” design, high safety and severe controls of the performances during the tests. The broad variety of heads execution offers a wide selection of dosing pumps to cover practically any application needs. In addition the full compliance with the **ATEX** European Directive gives the possibility to install these pumps in classified areas too.

Mechanism

Available in different sizes, they are mechanical return type, giving the maximum reliability in all working conditions.

General Specifications:

- Low noise integral gearbox, worm type, oil bath lubricated
- Reduced energy consumption based on low friction rolling bearings design
- High flexibility multiple mechanism solution to permit different piston speeds (SPM) on the same group
- Micrometric stroke length adjustment both manually and/or automatically actuated.
- Automatic stroke length variation by electrical servomotor, pneumatic actuator or frequency converter.
- Linearity and repeatability in compliance with API 675 Standards.
- Easy “on field” installation of electrical servomotor on manual stroke adjustment mechanism.

Plunger Pumphead:

- Reliable and easy maintenance
- Ready for flushing connection or for leakage recovery system connection
- Plunger coating or mechanical surface hardening for heavy-duty application

PUMP KEY CODE

1°	Number of pump head					
1	Simplex pump					
2°	Type of pump head (double diaphragm or packed-plunger)					
P	Packed plunger with square section rings					
3°/4°	Plunger diameter					
06+35	from 6 to 35 mm					
5°/6°	Mechanism model					
NO	Stroke length 10 mm					
7°/8°	Pump head materia l					
	HEAD	PLUNGER	SEAL PACK	BALL	VALVE SEAL	VALVE SEAT
1A	316SS	316SS + CERAMIC	ARAMIDIC FIBER	316SS	316SS	316SS
7Y	316SS	316SS	PTFE	316SS	316SS	316SS
9°	Valve type					
A	Single ball					
B	Double balls					
C	Triple balls					
10°	General options					
7	Standard execution					
F	Flanged connections ANSI B16.5					
11°	Flow rate adjustment					
M	Manual with adjustment knob (Standard execution)					
E	Electric actuator					
P	Pneumatic actuator					
12°	Gear ratio					
F	1:15					
I	1:20					
L	1:25					
13°	Electric motors poles					
2	2 poles (not available ATEX version)					
4	4 poles					
6	6 poles					
14°	Installed power					
B	0,18 kW					
15°	Pump head options					
F	Flushing connections					
16°	Mechanism options					
0	Standard execution					
5	Compliance with regulation "ATEX" 94/4/CE II 2 G c IIB T4 (for zone 1) (*)					

1	P	06	NO	1A	C	7	M	L	6	B	F	0
---	---	----	----	----	---	---	---	---	---	---	---	---

(*) for toxic, inflammable, hazardous and/or pyrophoric liquids packed plunger pumps are not suitable.

HYDRAULIC CHARACTERISTICS

Performances:										50 Hz			60Hz			Liquid end material		316L					
										0,596/61,4 40/20			l/h bar			gph 0,203/20,9 p.s.i. 580/290							
										Flow rate at max pressure			Max speed			Flow rate at max pressure		Max speed		Electric motor kW 0,18 B		Suc/Dis Connec	
Pump Model										Strokes			Strokes			Max pressure		Ø BSSP	NPSHr [barg]				
										lph gph /min			lph gph /min			bar p.s.i.							
1 P 0 6 N 0 1 A C 7 M L 6 B F 0	0,596	0,157	37	0,715	0,189	44	40	580	1/4" F	-0,50													
1 P 0 6 N 0 1 A C 7 M L 4 B F 0	0,757	0,200	47	0,908	0,240	56	40	580	1/4" F	-0,50													
1 P 0 6 N 0 1 A C 7 M L 4 B F 0	0,903	0,239	56	1,084	0,286	67	40	580	1/4" F	-0,50													
1 P 0 6 N 0 1 A C 7 M I 4 B F 0	1,128	0,298	70	1,354	0,358	84	40	580	1/4" F	-0,50													
1 P 0 6 N 0 1 A C 7 M F 4 B F 0	1,499	0,396	93	1,799	0,475	112	40	580	1/4" F	-0,50													
1 P 0 6 N 0 1 A C 7 M L 2 B F 0	1,805	0,477	112	2,166	0,572	134	40	580	1/4" F	-0,50													
1 P 0 8 N 0 1 A C 7 M L 6 B F 0	1,35	0,36	47	1,62	0,43	56	40	580	1/4" F	-0,50													
1 P 0 8 N 0 1 A C 7 M L 4 B F 0	1,60	0,42	56	1,92	0,51	67	40	580	1/4" F	-0,50													
1 P 0 8 N 0 1 A C 7 M I 4 B F 0	2,01	0,53	70	2,41	0,64	84	40	580	1/4" F	-0,50													
1 P 0 8 N 0 1 A C 7 M F 4 B F 0	2,66	0,70	93	3,19	0,84	112	40	580	1/4" F	-0,50													
1 P 0 8 N 0 1 A C 7 M L 2 B F 0	3,21	0,85	112	3,85	1,02	134	40	580	1/4" F	-0,50													
1 P 1 0 N 0 1 A C 7 M L 6 B F 0	2,10	0,55	47	2,52	0,67	56	40	580	1/4" F	-0,50													
1 P 1 0 N 0 1 A C 7 M L 4 B F 0	2,51	0,66	56	3,01	0,80	67	40	580	1/4" F	-0,50													
1 P 1 0 N 0 1 A C 7 M I 4 B F 0	3,13	0,83	70	3,76	0,99	84	40	580	1/4" F	-0,50													
1 P 1 0 N 0 1 A C 7 M F 4 B F 0	4,16	1,10	93	4,99	1,32	112	40	580	1/4" F	-0,50													
1 P 1 0 N 0 1 A C 7 M L 2 B F 0	5,01	1,32	112	6,01	1,59	134	40	580	1/4" F	-0,50													
1 P 1 2 N 0 1 A C 7 M L 6 B F 0	3,03	0,80	47	3,64	0,96	56	40	580	1/4" F	-0,50													
1 P 1 2 N 0 1 A C 7 M L 4 B F 0	3,61	0,95	56	4,33	1,14	67	40	580	1/4" F	-0,50													
1 P 1 2 N 0 1 A C 7 M I 4 B F 0	4,51	1,19	70	5,41	1,43	84	40	580	1/4" F	-0,50													
1 P 1 2 N 0 1 A C 7 M F 4 B F 0	6,00	1,59	93	7,20	1,90	112	40	580	1/4" F	-0,50													
1 P 1 2 N 0 1 A C 7 M L 2 B F 0	7,22	1,91	112	8,66	2,29	134	40	580	1/4" F	-0,50													
1 P 1 5 N 0 1 A B 7 M L 6 B F 0	4,73	1,25	47	5,68	1,50	56	40	580	1/4" F	-0,50													
1 P 1 5 N 0 1 A B 7 M L 4 B F 0	5,64	1,49	56	6,77	1,79	67	40	580	1/4" F	-0,50													
1 P 1 5 N 0 1 A B 7 M I 4 B F 0	7,05	1,86	70	8,46	2,23	84	40	580	1/4" F	-0,50													
1 P 1 5 N 0 1 A B 7 M F 4 B F 0	9,37	2,48	93	11,24	2,97	112	40	580	1/4" F	-0,50													
1 P 1 5 N 0 1 A B 7 M L 2 B F 0	11,28	2,98	112	13,54	3,58	134	40	580	1/4" F	-0,50													
1 P 2 0 N 0 1 A B 7 M L 6 B F 0	8,4	2,2	47	10,1	2,7	56	40	580	1/4" F	-0,50													
1 P 2 0 N 0 1 A B 7 M L 4 B F 0	10,0	2,6	56	12,0	3,2	67	40	580	1/4" F	-0,50													
1 P 2 0 N 0 1 A B 7 M I 4 B F 0	12,5	3,3	70	15,0	4,0	84	40	580	1/4" F	-0,50													
1 P 2 0 N 0 1 A B 7 M F 4 B F 0	16,7	4,4	93	20,0	5,3	112	40	580	1/4" F	-0,50													
1 P 2 0 N 0 1 A B 7 M L 2 B F 0	20,1	5,3	112	24,1	6,4	134	40	580	1/4" F	-0,50													
1 P 2 5 N 0 1 A B 7 M L 6 B F 0	10,4	2,7	37	12,5	3,3	44	40	580	1/4" F	-0,50													
1 P 2 5 N 0 1 A B 7 M L 4 B F 0	13,2	3,5	47	15,8	4,2	56	40	580	1/4" F	-0,50													
1 P 2 5 N 0 1 A B 7 M L 4 B F 0	15,7	4,1	56	18,8	5,0	67	40	580	1/4" F	-0,50													
1 P 2 5 N 0 1 A B 7 M I 4 B F 0	19,6	5,2	70	23,5	6,2	84	40	580	1/4" F	-0,50													
1 P 2 5 N 0 1 A B 7 M F 4 B F 0	26,0	6,9	93	31,2	8,2	112	40	580	1/4" F	-0,50													
1 P 2 5 N 0 1 A B 7 M L 2 B F 0	31,3	8,3	112	37,6	9,9	134	40	580	1/4" F	-0,50													
1 P 3 0 N 0 7 Y A 7 M L 6 B F 0	14,9	3,9	37	17,9	4,7	44	28	406	1/4" F	-0,50													
1 P 3 0 N 0 7 Y A 7 M L 4 B F 0	18,9	5,0	47	22,7	6,0	56	28	406	1/4" F	-0,50													
1 P 3 0 N 0 7 Y A 7 M L 4 B F 0	22,6	6,0	56	27,1	7,2	67	28	406	1/4" F	-0,50													
1 P 3 0 N 0 7 Y A 7 M I 4 B F 0	28,2	7,4	70	33,8	8,9	84	28	406	1/4" F	-0,50													
1 P 3 0 N 0 7 Y A 7 M F 4 B F 0	37,5	9,9	93	45,0	11,9	112	28	406	1/4" F	-0,50													
1 P 3 0 N 0 7 Y A 7 M L 2 B F 0	45,1	11,9	112	54,1	14,3	134	27	392	1/4" F	-0,50													
1 P 3 5 N 0 7 Y A 7 M L 6 B F 0	20,3	5,4	37	24,4	6,4	44	20	290	1/4" F	-0,50													
1 P 3 5 N 0 7 Y A 7 M L 4 B F 0	25,8	6,8	47	31,0	8,2	56	20	290	1/4" F	-0,50													
1 P 3 5 N 0 7 Y A 7 M L 4 B F 0	30,7	8,1	56	36,8	9,7	67	20	290	1/4" F	-0,50													
1 P 3 5 N 0 7 Y A 7 M I 4 B F 0	38,4	10,1	70	46,1	12,2	84	20	290	1/4" F	-0,50													
1 P 3 5 N 0 7 Y A 7 M F 4 B F 0	51,0	13,5	93	61,2	16,2	112	20	290	1/4" F	-0,50													
1 P 3 5 N 0 7 Y A 7 M L 2 B F 0	61,4	16,2	112	73,7	19,5	134	20	290	1/4" F	-0,50													

Test with water @ 20°C.

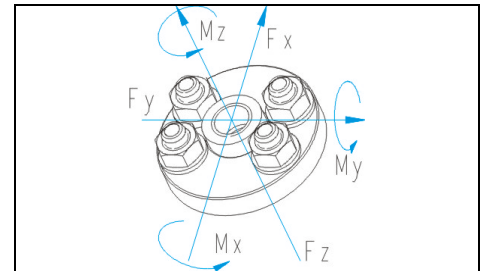
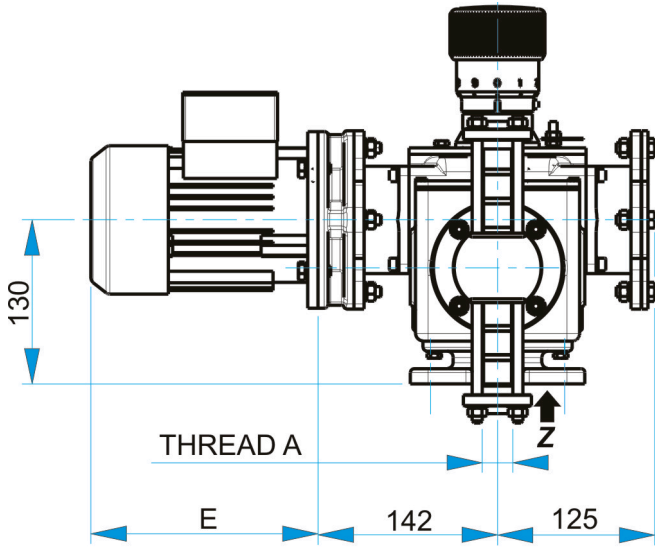

Allowable loads referred to pump nozzles

Fx	0.10 kN	Mx	0.04 kNm
Fy	0.12 kN	My	0.04 kNm
Fz	0.10 kN	Mz	0.04 kNm

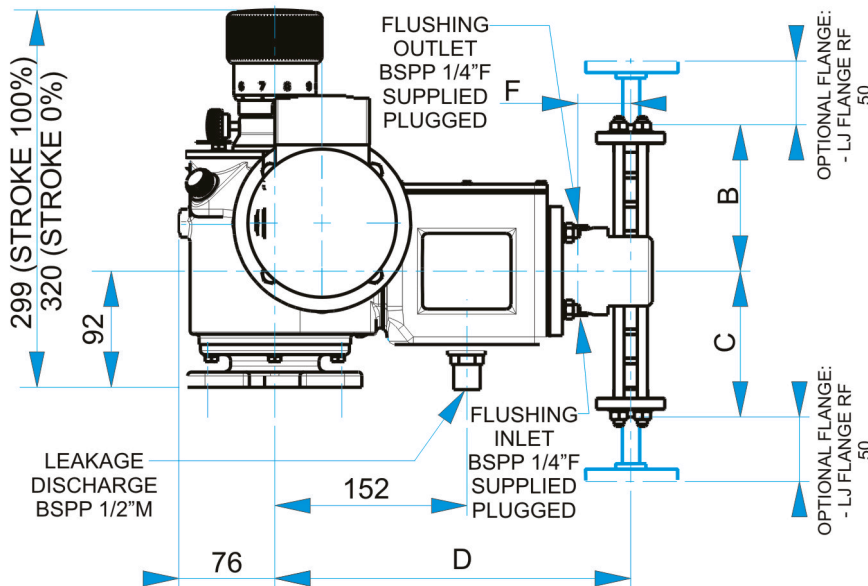

FIXING HOLES – VIEW FROM Z

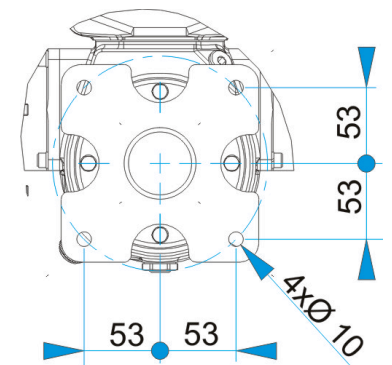

PUMP MODEL	DIMENSIONS [mm]					ESTIMATED WEIGHT kg (without motor)	OPTIONAL FLANGE ANSI 300 MAX. TEMP. 38°C MAX. PRESSURE 40BAR SIZE
	A	B	C	D	F		
1P06N01AC..	BSPP 1/4"F	116	116	283	42	28	1/2"
1P08N01AC..	BSPP 1/4"F	116	116	283	42	28	1/2"
1P10N01AC..	BSPP 1/4"F	116	116	303	49	29	1/2"
1P12N01AC..	BSPP 1/4"F	116	116	303	49	29	1/2"
1P15N01AB..	BSPP 1/4"F	93	93	303	49	29	1/2"
1P20N01AB..	BSPP 1/4"F	116	116	316	53	29	1/2"
1P25N01AB..	BSPP 1/4"F	116	116	316	53	29	1/2"
1P30N07YA..	BSPP 1/4"F	98	98	316	53	33	1/2"
1P35N07YA..	BSPP 1/4"F	98	98	319	56	33	1/2"

Electric motor size	2 Poles kw	4 Poles kw	6 Poles kw	TEFC 1xM16x1.5		EExde 1xM25x1.5	
				E	kg	E	kg
63	0.18	0.18	0.18	193	4	224	16