

Technical characteristics

- Flow rates: from 77 to 593 lph @ 50Hz
- Max Pressure: 12 MPa (120 bar)
- Ambient temperature: -10 °C + 40 °C
- Max altitude: 1000 m (A.S.L.)
- Fluid operating temperature: -10 °C + 70 °C
- Viscosity up to 1000 mPa*s (1000 cP) (Higher on request)
- Stroke adjustment during operation from 0 to 100%
- Accuracy $\pm 1\%$ on the turndown ratio 10:1
- Built-in overpressure valve
- Double diaphragm and diagnostic of the rupture
- Diaphragm duration up to 20.000 hours, depending of the application
- Multiheads (up to six) solutions
- API 675 compliance
- CE marking
- ATEX Ex II 2 G c IIB T4 compliance
- Protection: IP 55
- Epoxy painting at 125 micron

nexa series includes plunger and hydraulic diaphragm dosing pumps designed in compliance with **API 675 Standards**; the conformity to the API Standards implies a “heavy duty” design, high safety and severe controls of the performances during the tests. The broad variety of heads execution offers a wide selection of dosing pumps to cover practically any application needs. In addition the full compliance with the **ATEX** European Directive gives the possibility to install these pumps in classified areas too.

Mechanism

Available in different sizes, they are mechanical return type, giving the maximum reliability in all working conditions.

General Specifications:

- Low noise integral gearbox, worm type, oil bath lubricated
- Reduced energy consumption based on low friction rolling bearings design
- High flexibility multiple mechanism solution to permit different piston speeds (SPM) on the same group
- Micrometric stroke length adjustment both manually and/or automatically actuated.
- Automatic stroke length variation by electrical servomotor, pneumatic actuator or frequency converter
- Linearity and repeatability in compliance with API 675 Standards.
- Easy “on field” installation of electrical servomotor on manual stroke adjustment mechanism.

Diaphragm Pumphead

- High capacity flexibility → On site easy volume changing by changing the piston cartridge
- Easy to change spares parts (all “one cartridge” solution).
- Maximum compatibility PTFE diaphragm
- Visual or remote diaphragm failure detection

PUMP KEY CODE

1°	Number of pump head									
1	Simplex pump									
2°	Type of pump head (double diaphragm or packed-plunger)									
T	Double diaphragm with built-in overpressure valve, air-bleed valve and mechanically actuated oil replenishing									
3°/4°	Plunger diameter									
25+50	25 - 35 - 50 mm									
5°/6°	Mechanism model									
N3	Stroke length 50 mm									
7°/8°	Pump head material									
2F	HEAD	DIAPHRAGM	BALL	VALVE SEAL	VALVE SEAT					
	316SS	PTFE	316SS	316SS	316SS					
9°	Valve type									
B	Double balls									
10°	General options									
7	Standard execution									
11°	Flow rate adjustment									
M	Manual with adjustment knob (Standard execution)									
E	Electric actuator									
P	Pneumatic actuator									
12°	Gear ratio									
D	1:12									
F	1:15									
13°	Electric motors poles									
4	4 poles									
6	6 poles									
14°	Installed power									
K	4,00 kW (230 ÷ 400Vac)									
L	5,50 kW (400 ÷ 690Vac)									
M	7,50 kW (400 ÷ 690Vac)									
15°	Pump head options									
V	Visual diaphragm failure detection (Standard execution)									
R	Remote diaphragm failure detection									
16°	Mechanism options									
0	Standard execution									
5	Compliance with regulation "ATEX" 94/4/CE II 2 G c IIB T4 (for zone 1)									

1	T	25	N3	2F	B	7	M	F	6	K	V	0
---	---	----	----	----	---	---	---	---	---	---	---	---

HYDRAULIC CHARACTERISTICS

Performances:										50 Hz		60Hz																									
										77/593 120/76		l/h bar		gph p.s.i.		25/188 1740/1102		Liquid end material				316L															
										Flow rate at max pressure		Max speed		Flow rate at max pressure		Max speed		Electric motor kW						Suc/Dis Connec													
																		4,0 K		5,5 L		7,5 M															
Pump Model										lph		gph		Strokes /min		lph		gph		Strokes /min		Max pressure						Ø BSPP		NPSHr [barg]							
																						bar		p.s.i.		bar		p.s.i.		bar		p.s.i.					
1	T	2	5	N	3	2	F	B	7	M	F	6	K	V	0	77	20	62	93	25	74	120	1740	-	-	-	-	-	-	-	-	3/4" F	-0,70				
1	T	2	5	N	3	2	F	B	7	M	D	6	K	V	0	97	26	78	116	31	94	120	1740	-	-	-	-	-	-	-	-	3/4" F	-0,70				
1	T	2	5	N	3	2	F	B	7	M	F	4	L	V	0	115	30	93	138	36	112	-	-	120	1740	-	-	-	-	-	-	3/4" F	-0,70				
1	T	2	5	N	3	2	F	B	7	M	D	4	L	V	0	144	38	117	173	46	140	-	-	120	1740	-	-	-	-	-	-	3/4" F	-0,70				
1	T	3	5	N	3	2	F	A	7	M	F	6	K	V	0	159	42	62	191	50	74	120	1740	-	-	-	-	-	-	-	-	3/4" F	-0,60				
1	T	3	5	N	3	2	F	A	7	M	D	6	L	V	0	200	53	78	240	63	94	-	-	120	1740	-	-	-	-	-	-	3/4" F	-0,60				
1	T	3	5	N	3	2	F	A	7	M	F	4	L	V	0	238	63	93	286	75	112	-	-	120	1740	-	-	-	-	-	-	3/4" F	-0,60				
1	T	3	5	N	3	2	F	A	7	M	D	4	M	V	0	299	79	117	359	95	140	-	-	-	-	120	1740	-	-	-	-	3/4" F	-0,60				
1	T	5	0	N	3	2	F	A	7	M	F	6	K	V	0	331	87	62	397	105	74	76	1102	-	-	-	-	-	-	-	-	1" F	-0,55				
1	T	5	0	N	3	2	F	A	7	M	D	6	L	V	0	407	108	78	488	129	94	-	-	76	1102	-	-	-	-	-	-	1" F	-0,55				
1	T	5	0	N	3	2	F	A	7	M	F	4	M	V	0	478	126	93	574	152	112	-	-	-	-	76	1102	-	-	-	-	1" F	-0,55				
1	T	5	0	N	3	2	F	A	7	M	D	4	M	V	0	593	157	117	712	188	140	-	-	-	-	76	1102	-	-	-	-	1" F	-0,55				

Test with water @ 20°C.

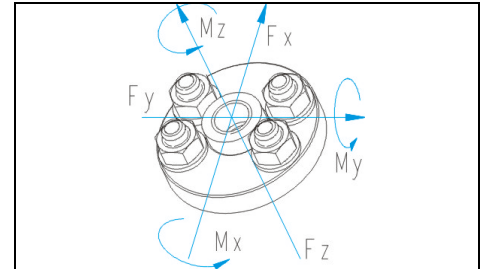
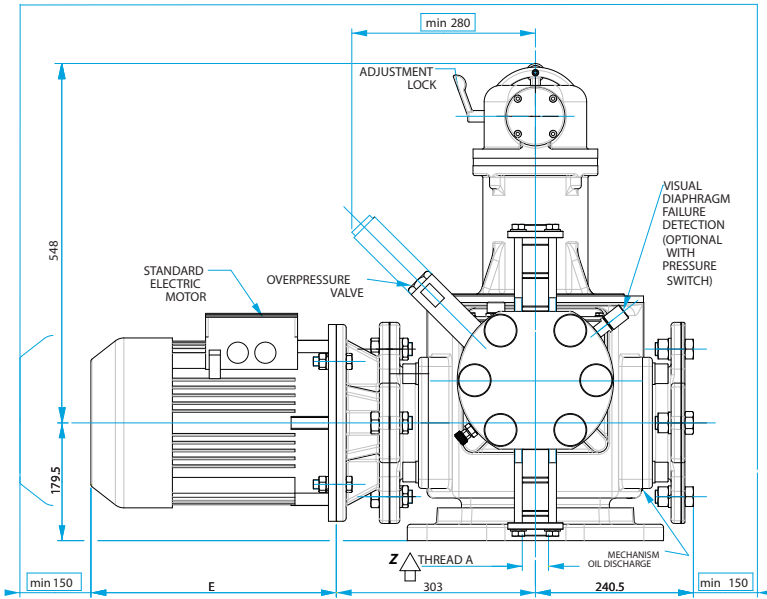

Allowable loads referred to pump nozzles

F _x	0.10 kN	M _x	0.04 kNm
F _y	0.12 kN	M _y	0.04 kNm
F _z	0.10 kN	M _z	0.04 kNm

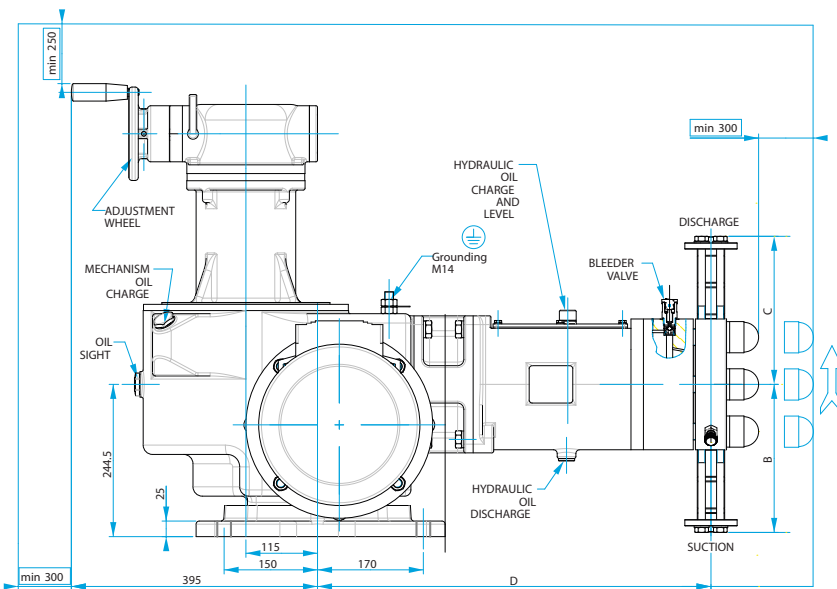

FIXING HOLES – VIEW FROM Z

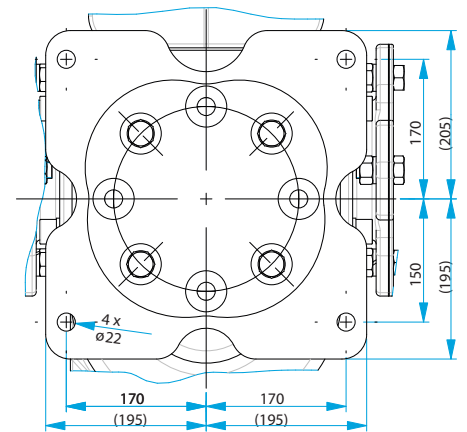

PUMP MDEL	DIMENSIONS [mm]				EXTIMATED WEIGHT kg (without motor)
	A (EN10226)	B	C	D	
1T25N32FB..	BSPP 3/4" F	238	238	632	340
1T35N32FB..	BSPP 3/4" F	238	238	632	340
1T50N32FB..	BSPP 1" F	310	310	640	372

Electric motor size	4 Poles kw	6 Poles kw	TEFC 1xM20x1.5		EExde 1xM25x1.5	
			E	kg	E	kg
132	5.50*	4.00*	435	78	585	95
132	7.50*	5.50*	435	78	585	95

* for motor voltage detail refer to Pump Key Code