

## Technical characteristics

- Flow rates: from 664 to 2515 lph @ 50Hz
- Max Pressure: 1,2 MPa (12 bar)
- Ambient temperature: -10 °C + 40 °C
- Max altitude: 1000 m (A.S.L.)
- Fluid operating temperature: -5 °C + 50 °C
- Viscosity up to 1000 mPa•s (1000 cP) (Higher on request)
- Stroke adjustment during operation from 0 to 100%
- Accuracy  $\pm 1\%$  on the turndown ratio 10:1
- Built-in overpressure valve
- Double diaphragm and diagnostic of the rupture
- Diaphragm duration up to 20.000 hours, depending of the application
- Multiheads (up to six) solutions
- API 675 compliance
- CE marking
- ATEX  II 2 G c IIB T4 compliance
- Protection: IP 55
- Epoxy painting at 125 micron

**nEXa series** includes plunger and hydraulic diaphragm dosing pumps designed in compliance with **API 675 Standards**; the conformity to the API Standards implies a “heavy duty” design, high safety and severe controls of the performances during the tests. The broad variety of heads execution offers a wide selection of dosing pumps to cover practically any application needs. In addition the full compliance with the **ATEX** European Directive gives the possibility to install these pumps in classified areas too.

## Mechanism

Available in different sizes, they are mechanical return type, giving the maximum reliability in all working conditions.

General Specifications:

- Low noise integral gearbox, worm type, oil bath lubricated
- Reduced energy consumption based on low friction rolling bearings design
- High flexibility multiple mechanism solution to permit different piston speeds (SPM) on the same group
- Micrometric stroke length adjustment both manually and/or automatically actuated.
- Automatic stroke length variation by electrical servomotor, pneumatic actuator or frequency converter
- Linearity and repeatability in compliance with API 675 Standards.
- Easy “on field” installation of electrical servomotor on manual stroke adjustment mechanism.

## Diaphragm Pumphead

- High capacity flexibility → On site easy volume changing by changing the piston cartridge
- Easy to change spares parts (all “one cartridge” solution).
- Maximum compatibility PTFE diaphragm
- Visual or remote diaphragm failure detection

### PUMP KEY CODE

1°	Number of pump head				
1	Simplex pump				
2°	Type of pump head (double diaphragm or packed-plunger)				
Y	Double diaphragm with built-in overpressure valve, air-bleed valve and mechanically actuated oil replenishing				
3°/4°	Plunger diameter				
70÷A0	70 - A0(100) mm				
5°/6°	Mechanism model				
N3	Stroke length 50 mm				
7°/8°	Pump head material				
5B	HEAD	DIAPHRAGM	BALL	VALVE SEAL	VALVE SEAT
	PP	PTFE	CERAMIC	FPM	FPM
9°	Valve type				
A	Single ball				
10°	General options				
7	Standard execution				
F	Flanged connections (UNI EN 1092-1)				
11°	Flow rate adjustment				
M	Manual with adjustment knob (Standard execution)				
E	Electric actuator				
P	Pneumatic actuator				
12°	Gear ratio				
D	1:12				
F	1:15				
13°	Electric motors poles				
4	4 poles				
6	6 poles				
14°	Installed power				
K	4,00 kW (230 ÷ 400Vac)				
L	5,50 kW (400 ÷ 690Vac)				
M	7,50 kW (400 ÷ 690Vac)				
15°	Pump head options				
V	Visual diaphragm failure detection (Standard execution)				
R	Remote diaphragm failure detection				
16°	Mechanism options				
0	Standard execution				
5	Compliance with regulation "ATEX" 94/4/CE II 2 G c. IIB T4 (for zone 1)				

  

1	Y	70	N3	5B	A	7	M	F	6	K	V	0
---	---	----	----	----	---	---	---	---	---	---	---	---

### HYDRAULIC CHARACTERISTICS

Performances:		50 Hz		60Hz								Liquid end material		PP															
		664/2515		l/h 12 bar		gph 211/797		p.s.i. 174																					
		Flow rate at max pressure	Max speed	Flow rate at max pressure	Max speed	Electric motor kW						Suc/Dis Connec																	
						4,0 K		5,5 L		7,5 M																			
Pump Model		lph gph		Strokes /min		lph gph		Strokes /min		Max pressure						Ø BSPP	NPSHr [barg]												
										bar	p.s.i.	bar	p.s.i.	bar	p.s.i.														
1	Y	7	0	N	3	5	B	A	7	M	F	6	K	V	0	664	175	62	797	211	74	12	174	-	-	-	-	1" F	-0,40
1	Y	7	0	N	3	5	B	A	7	M	D	6	L	V	0	829	219	78	995	263	94	-	-	12	174	-	-	1" F	-0,40
1	Y	7	0	N	3	5	B	A	7	M	F	4	M	V	0	984	260	93	1181	312	112	-	-	-	-	12	174	1" F	-0,40
1	Y	7	0	N	3	5	B	A	7	M	D	4	M	V	0	1231	325	117	1477	390	140	-	-	-	-	12	174	1" F	-0,40
1	Y	A	0	N	3	5	B	A	7	M	F	6	K	V	0	1324	350	62	1589	420	74	12	174	-	-	-	-	1-1/2" F	-0,50
1	Y	A	0	N	3	5	B	A	7	M	D	6	L	V	0	1671	441	78	2005	530	94	-	-	12	174	-	-	1-1/2" F	-0,50
1	Y	A	0	N	3	5	B	A	7	M	F	4	M	V	0	1995	527	93	2394	632	112	-	-	-	-	12	174	1-1/2" F	-0,50
1	Y	A	0	N	3	5	B	A	7	M	D	4	M	V	0	2515	664	117	3018	797	140	-	-	-	-	12	174	1-1/2" F	-0,50

Test with water @ 20°C.

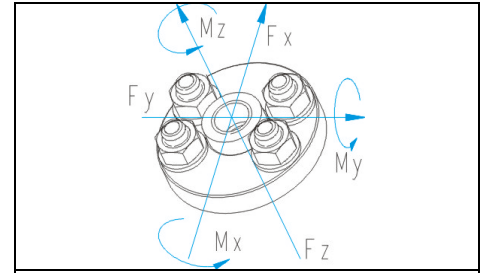
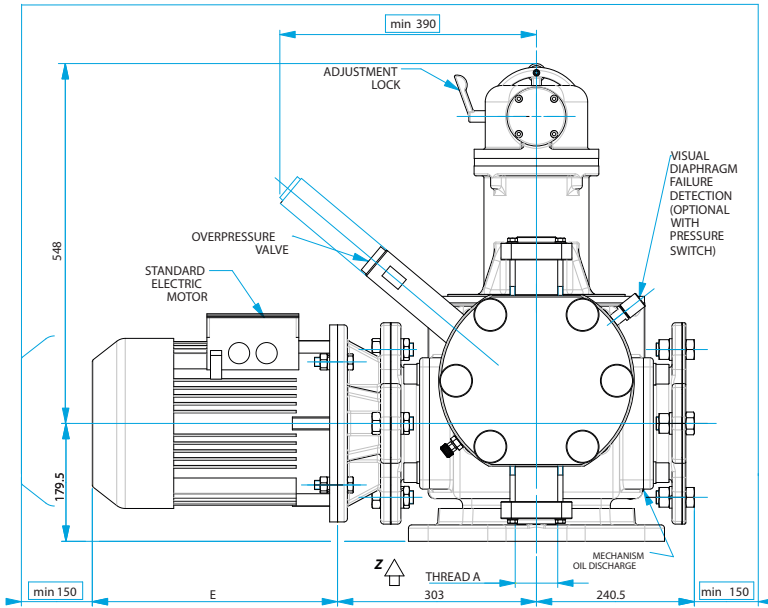

Allowable loads referred to pump nozzles

Fx	0.10 kN	Mx	0.04 kNm
Fy	0.12 kN	My	0.04 kNm
Fz	0.10 kN	Mz	0.04 kNm

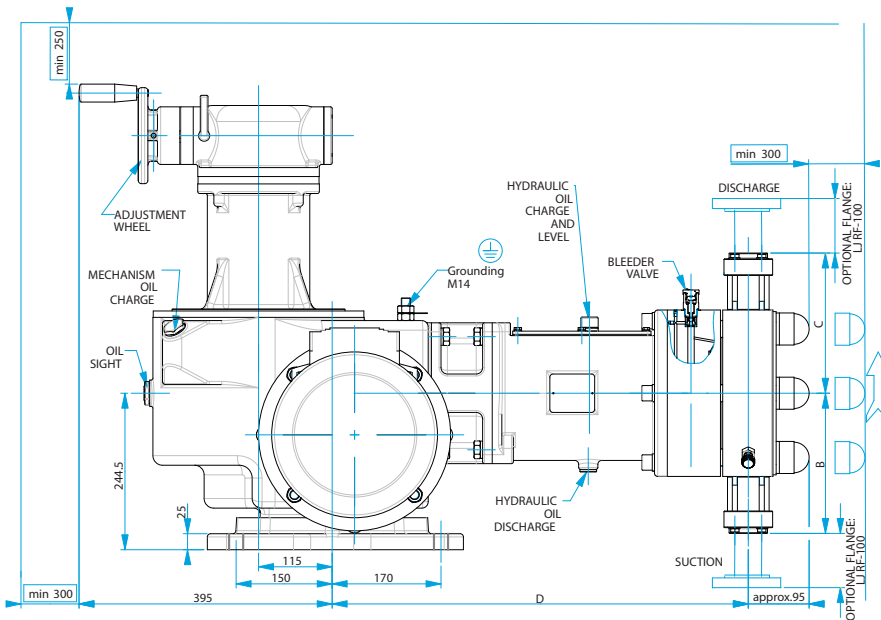

FIXING HOLES – VIEW FROM Z

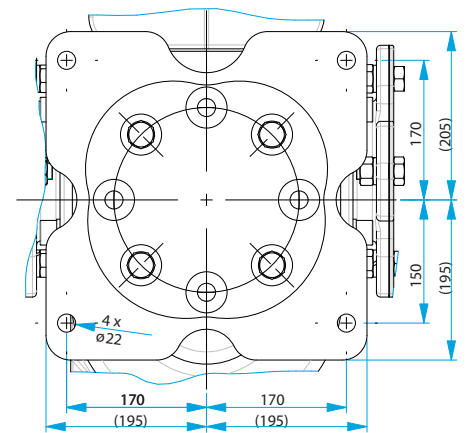

PUMP MDEL	DIMENSIONS [mm]				EXTIMATED WEIGHT kg (without motor)	OPTIONAL FLANGE PN10 MAX. TEMP. 40°C SIZE
	A (EN10226)	B	C	D		
1Y70N25BA..	BSPP 1"F	217	217	650	341	DN25
1YA0N25BA..	BSPP 1 1/2"F	285	285	667	353	DN40

Electric motor size	4 Poles kw	6 Poles kw	TEFC 1xM20x1.5		EExde 1xM25x1.5	
			E	kg	E	kg
132	5.50*	4.00*	435	78	585	95
132	7.50*	5.50*	435	78	585	95

\* for motor voltage detail refer to Pump Key Code